



BVW-200/300/400
BETACAM SP ONE-PIECE CAMCORDER
(NTSC)

PRODUCTS INFORMATION MANUAL



Contents

1. INTRODUCTION
2. HISTORY OF FIELD SHOOTING
 - 2-1. Early Days of ENG
 - 2-2. The Introduction of Betacam™ System
 - 2-3. The Introduction of Betacam SP System
 - 2-4. The Introduction of BVW-200 One-piece Camcorder
3. INNOVATION IN THE BVW-200/300/400
 - 3-1. One-piece Camcorder Internal Layout
 - 3-2. VTR Mechanical Features
 - 3-2-1. Small drum design
 - 3-2-2. Miniaturized tape transport mechanism
 - 3-3. VTR Electronic Features
 - 3-3-1. Plug-in PC board construction
 - 3-3-2. Software servo control IC
 - 3-3-3. Serial interface among CPU's
 - 3-3-4. High density circuit board
 - 3-3-5. LCD multiple displays
 - 3-4. Camera Technical Features
 - 3-4-1. Camera head construction
 - 3-4-2. Advanced Sony's CCD technology
4. EASY OPERATION
 - 4-1. Refined Ergonomics
 - 4-2. Rain and Dust-proof Structure
 - 4-3. Quick Start Viewfinder
 - 4-3-1. Optical/CRT
 - 4-3-2. Viewfinder mechanism
 - 4-3-3. Operational facilities
 - 4-4. Detachable Microphone
 - 4-5. Tally Lamp
 - 4-6. Battery for Time Code Back-up
 - 4-7. Other Operational Facilities
 - 4-7-1. VTR section
 - 4-7-2. Camera section
 - 4-7-3. Exclusive features for BVW-400
5. EASY MAINTENANCE AND ADVANCED SERVICEABILITY
6. EXCELLENT EXPANDABILITY
7. EXPLANATION OF BVW-200/300/400 FUNCTION KEYS AND BUTTONS
8. SPECIFICATIONS

1. INTRODUCTION

Betacam SP is now established as the world standard for the high quality acquisition, production, and distribution. Since its introduction, Sony's camcorder family has evolved to secure a position as the true workhorse for news and field production acquisitions. In addition to the widely accepted Combo Camcorders, Sony presented a revolutionary new approach to ENG (Electronic News Gathering) camcorder development with the BVW-200, the industry's first broadcast quality one-piece (inseparable) camcorder, at NAB '88. As a result of its great success and market acceptance, a high performance BVW-300 was introduced at NAB '89, aimed at both ENG and EFP (Electronic Field Production). Now, at NAB '90, Sony takes another step forward in ENG/EFP applications with an even higher performance one-piece camcorder, the BVW-400. These three units form a versatile product family which can satisfy any traditional video production needs as well as the most innovative requirements the video industry can generate.

While the decision to integrate the recorder and camera sections into one body provides a number of obvious advantages, it also requires a number of technical innovations. In this manual, the latest Betacam SP and CCD technology, and other major innovations used to realize the most compact one-piece camcorders will be described in detail.



2. HISTORY OF FIELD SHOOTING

Before delving into the technical and operational issues, let us briefly review the history of news coverage and Single Camera Production in the television industry.

2-1. Early Days of ENG

In the latter part of the 1970's, the first compact, portable cameras started to appear on the market. At about the same time, Sony's first U-matic portable recorders for broadcast applications became available. These two developments triggered the start of the transition from film to video news gathering or, as it came to be known, "Electronic News Gathering" (ENG). To some extent this also applied to what became known as "Electronic Field Production" (EFP).

Video overcame the fundamental drawback of 16mm film cameras, which were originally used for news coverage. From the actual field gathering point of view, film cameras were convenient, particularly with respect to size, weight, power consumption and overall simplicity and ruggedness. However, film was and still is limited by the over-riding disadvantage of being intrinsically a time delayed system—in other words, processing of the film is necessary before viewing or transmission is possible. Video achieved the immediacy so desirable for effective hard news coverage. Of course, this advancement was achieved at considerable sacrifice on the part of the news camera person. From carrying and operating a simple, small, lightweight and rugged system, he was saddled with a relatively bulky, complicated and more delicate system, involving a separate camera and a recorder with a cable.

2-2. The Introduction of Betacam System

The most notable recent advance in field acquisition has been the introduction of Betacam, half-inch analog component recording system, and 3-chip CCD cameras. Thanks to the advanced Betacam technology, high performance in a smaller package was possible. The camcorder concept that docked the camera and recorder in a single unit was born. The BVW-1, Sony's first Betacam camcorder, was introduced in 1982, and then the Sony BVW-3 camcorder, introduced in 1983, brought high quality pictures to news crews, while weighing only approximately 10.5 kg (23 lb 2 oz), fully loaded.

The introduction of CCD imaging devices and development of 3-chip CCD cameras allowed the replacement of the delicate camera tubes, and greatly reduced size, weight, power consumption and operational adjustment. The first CCD camcorder BVW-105, which was introduced in 1986, realized lighter operating weight, approximately 9.0 kg (19 lb 14 oz).

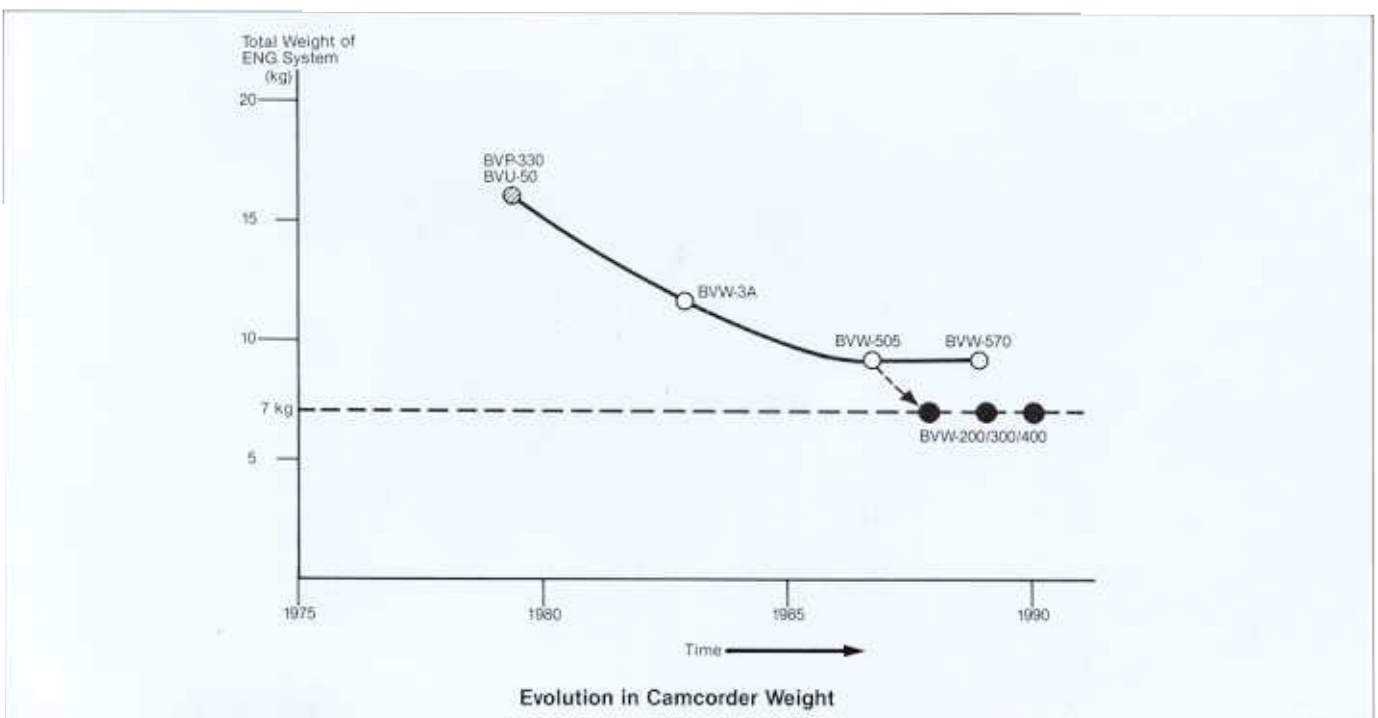

2-3. The Introduction of Betacam SP System

Following the introduction of Betacam, Betacam SP was announced in 1986 to improve overall quality covering the full range of broadcast applications from high quality ENG/EFP, to post production and transmission. The BVW-5 Recorder Unit and a wide range of 3-chip CCD camera combinations take full advantage of Betacam SP's enhanced recording technology and Sony's world leading CCD imaging technology. Betacam SP camcorders have found widespread applications throughout the world.

2-4. The Introduction of the BVW-200 One-piece Camcorder

Sony had consistently attempted to develop more ideal equipment for the news camera person and single camera operator. Many of the advantages and characteristics of the previous film cameras were incorporated in the development of the world's first one-piece camcorder, BVW-200, whose operating weight is only about 6.9 kg (15 oz 7 lb). In producing the BVW-200 camcorder, and subsequently the BVW-300/400, Sony has utilized all of the knowledge and techniques developed over the years, plus a great number of very innovative design techniques.

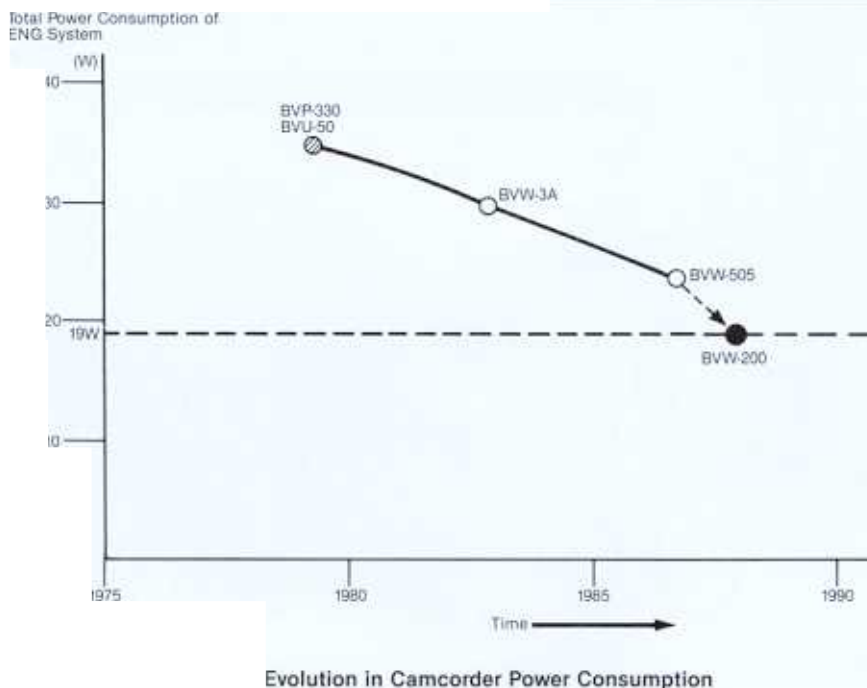
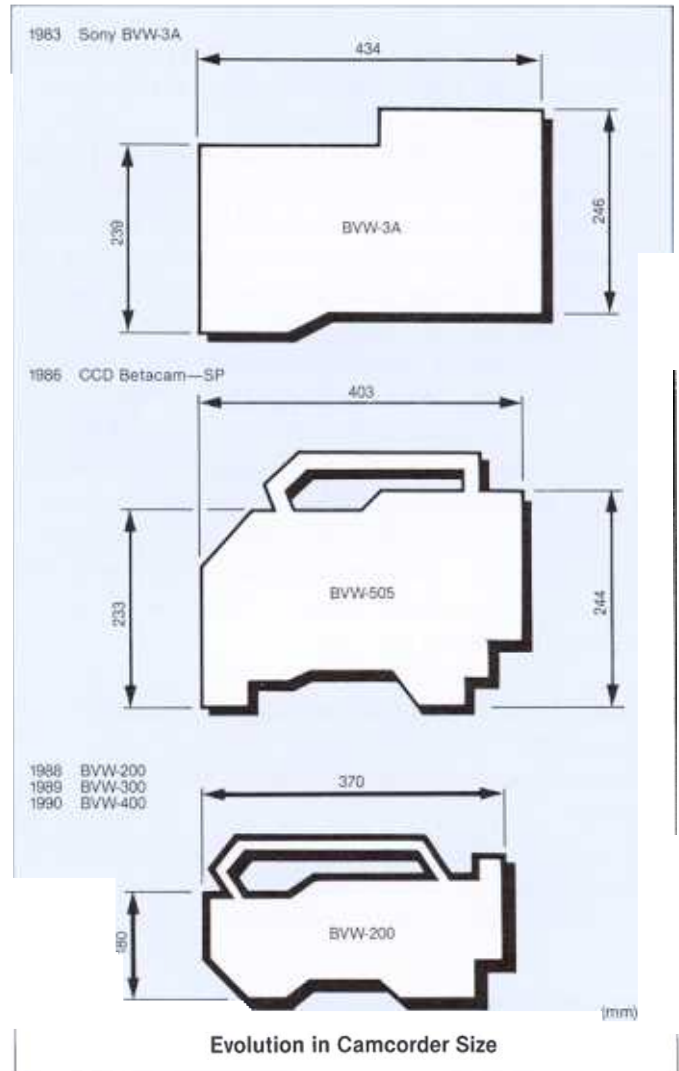

3. INNOVATION IN THE BVW-200/300/400

While Betacam SP Camcorders are now widely accepted in the broadcast and production industry, users have consistently requested the development of more compact and lightweight camcorders.

Considering the present ENG situation where a VTR and a camera are used in a unified way in almost all cases, a bold new design concept of an inseparable camcorder was used. This enabled realization of the greatly reduced size, weight, and power consumption. Of course, special attention was also paid to the other critical factors such as reliability, mobility, operational ease of use, flexibility, and serviceability. These key design decisions were made after close consultation between veteran ENG crews from major international broadcast organizations and Sony industrial designers as well as electrical and mechanical engineers. As a result of this collaboration, the Sony one-piece camcorder family encompasses the majority of the recommendations from the people who use these remarkable new tools.

Overall Characteristics of the Sony One-piece Camcorders

- Shoulder weight of less than 7 kg (15 lb 7 oz)—fully loaded
- Perfect balance—adjustable shoulder pad for different lens attachments and batteries
- Extremely low power consumption

- Shorter length and lower profile for better peripheral vision
- Quick start up and improved layout for all operational controls
- Uncompromised technical performance that fully exploits the inherent superiority of Betacam SP recording capability
- Freedom from daily technical alignment and easy maintenance
- Enhanced reliability

3-1. One-piece Camcorder Internal Layout

In the BVW-200/300/400, a remarkably efficient Internal layout has been achieved. These units are constructed so that the PC (Printed Circuit) boards for both camera and VTR sections plug into the main mother board. This feature eliminates the need for a wiring harness, which provides greater reliability than when many small boards are connected together. In addition, VTR circuit adjustments are more easily accessible than in previous camcorders. The preferred plug-in board type construction has been made possible by the extremely thin and highly miniaturised tape transport mechanism and drum assembly, as well as high density circuit boards using newly developed IC's.

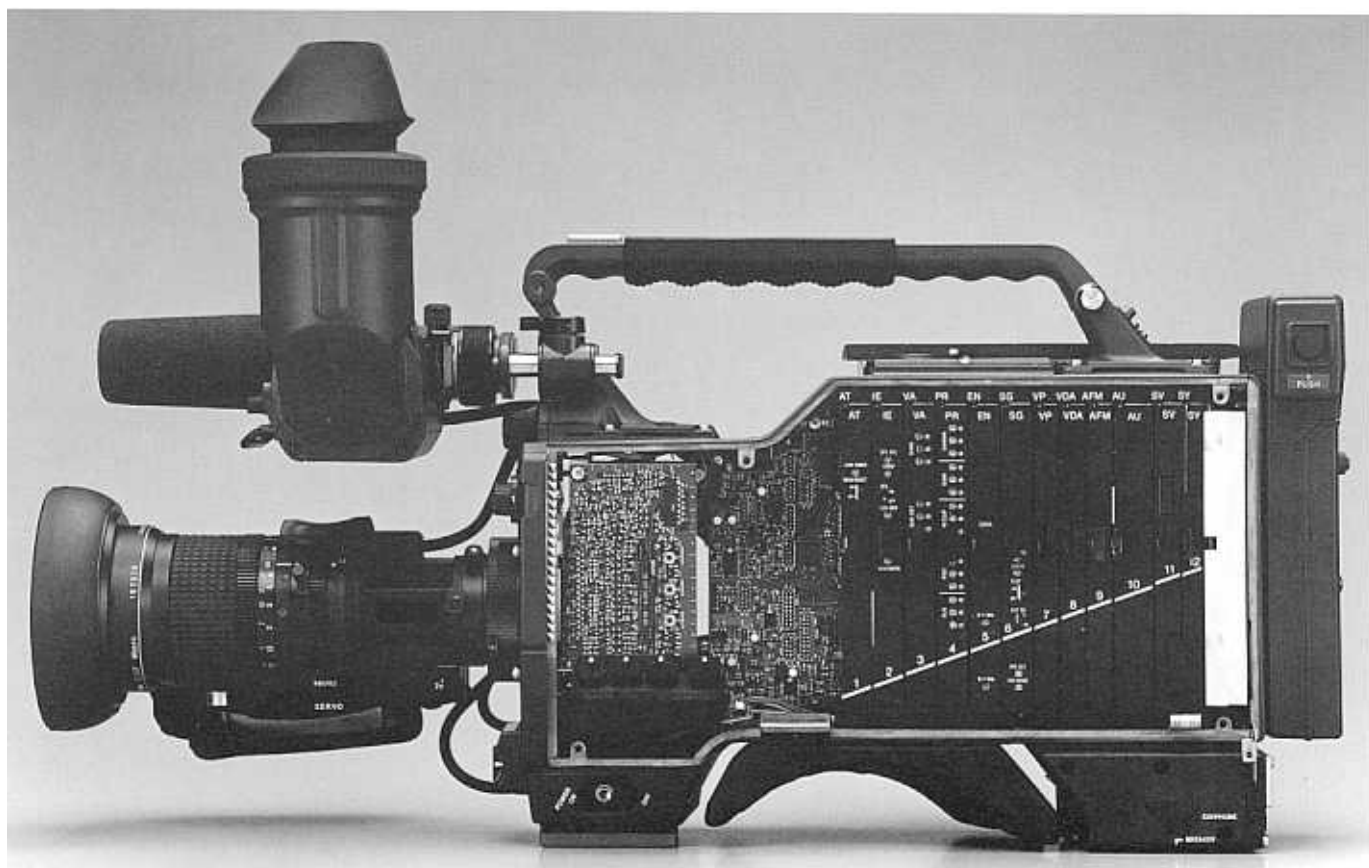

3-2 VTR Mechanical Features

3-2-1. Small drum design

In order to achieve the required compact size for the camcorder, the drum mechanism has been reduced in size. While the standard Betacam SP VTR's use a head drum with 2 heads for each of the Y and C channels, a 180 degree tape wrap angle, and rotation rate of about 30Hz, the BVW-200/300/400 adopt a head drum with a diameter of approximately $\frac{2}{3}$ standard size. It is fitted with 4 heads for each of the Y and C channels, and the tape is drawn around the drum by two moving guides, to produce a 270 degree tape wrap angle. The drum rotation rate is about 45Hz. The result is the same recorded track length and recorded angle as the standard Betacam SP format. The recorded format of the one-piece camcorders conforms to the Betacam SP format despite the difference in head-drum size. Of course, as Betacam SP and conventional Betacam have format compatibility, the one-piece camcorder family accepts either metal tapes or oxide tapes.

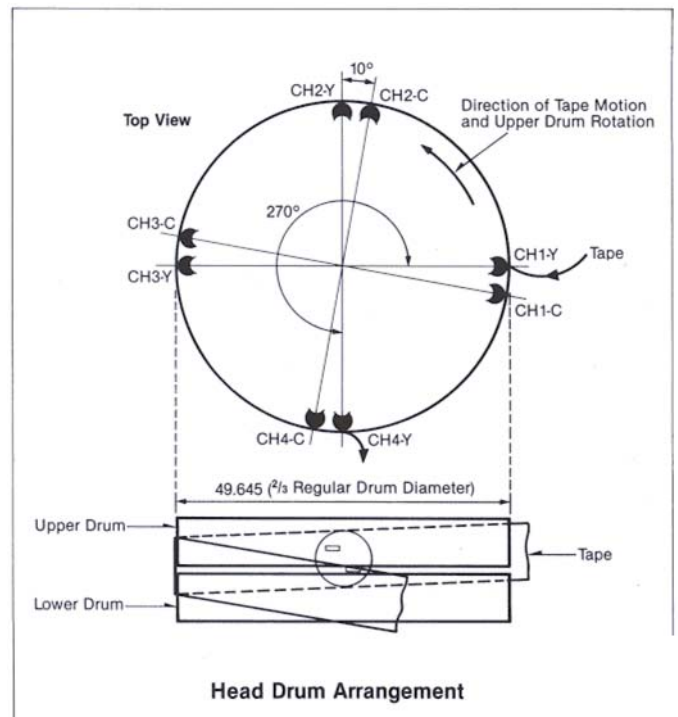
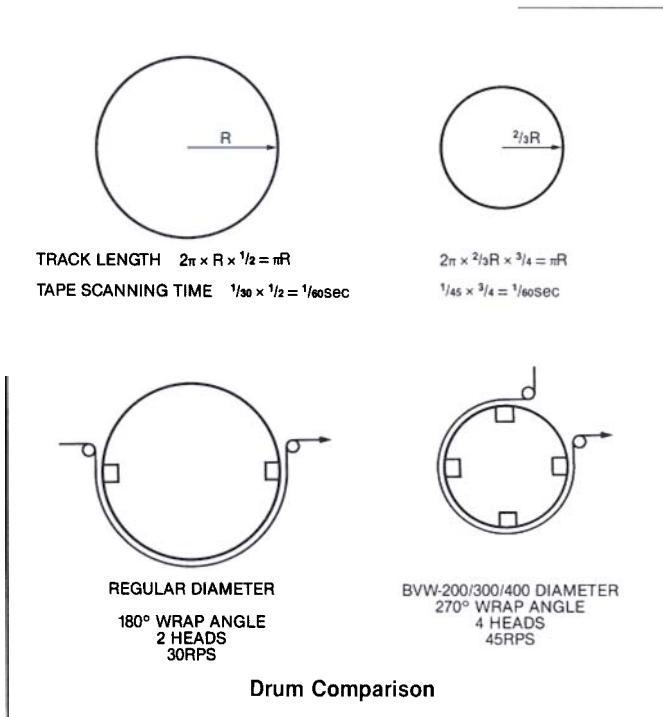
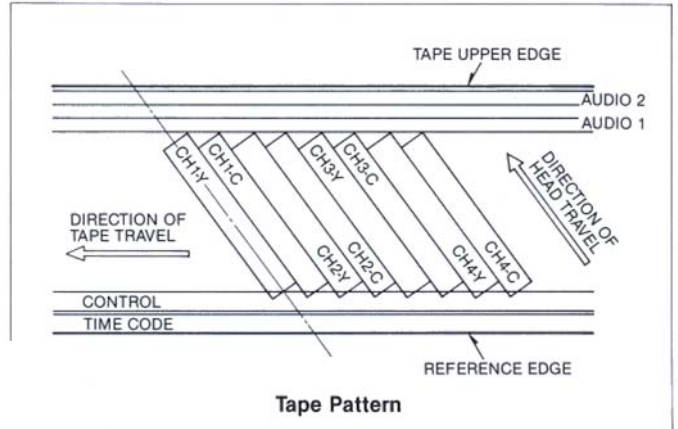

3-2-2. Miniaturized tape transport mechanism

In addition to the adoption of the small drum, the radical miniaturization of the VTR deck is largely attributed to the miniaturized tape transport mechanism. In order to save space in the tape deck, the cassette is shifted 15mm closer to the drum during loading. In this condition, the cassette shell partly overlaps the drum. Furthermore, a lower weight target for each main component such as the drum and capstan was set and achieved to reduce the overall VTR weight. In the conventional VTR's, the drum and capstan are slanted and project below the tape transport mechanism. However, in one-piece camcorders, these components are mounted parallel to the surface of the cassette so that the tape transport mechanism is flat and has no projection to interfere with the motherboard. As a result, the flat and thin VTR deck design allows the VTR deck itself and PC boards to plug into the motherboard on both sides.

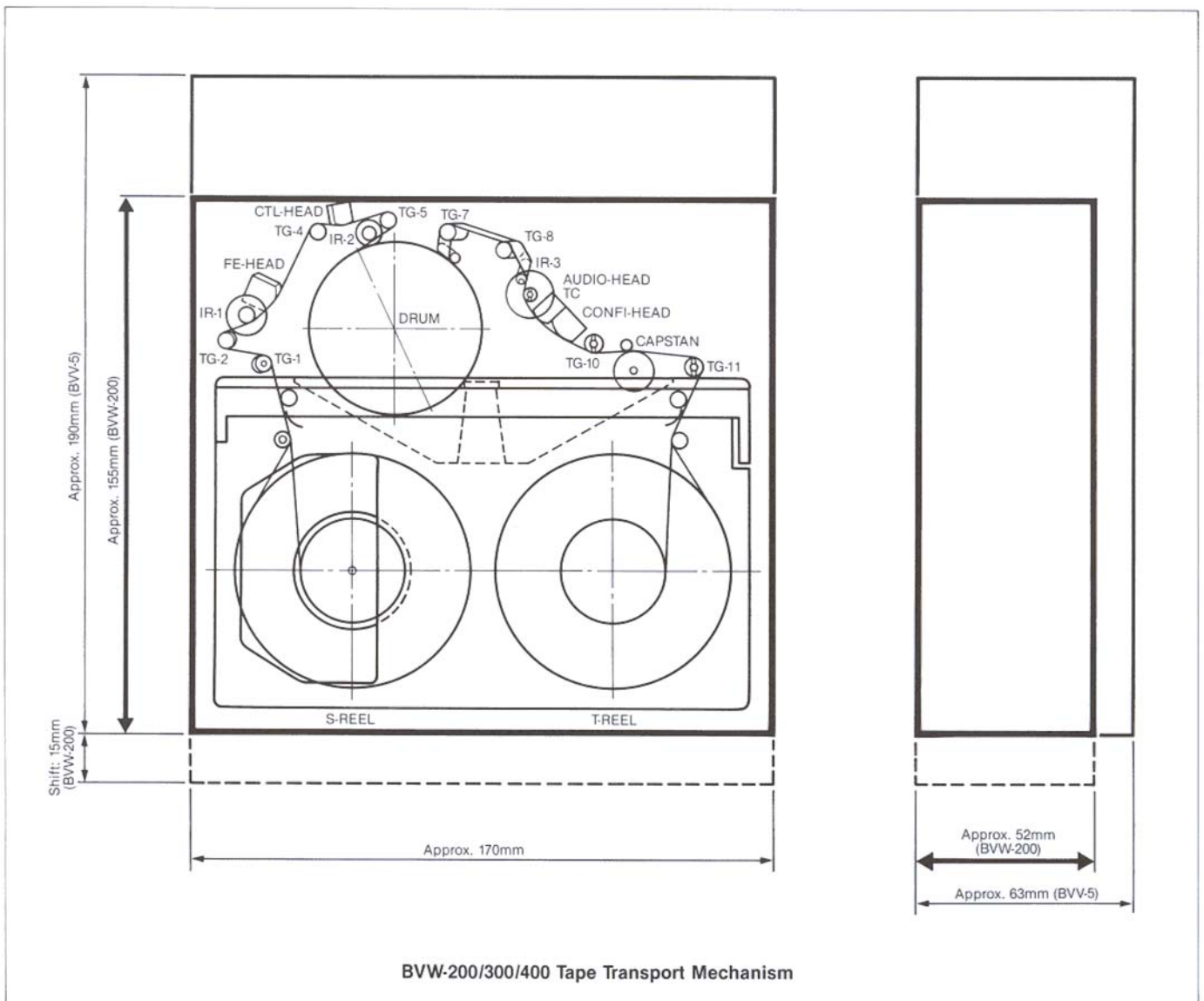
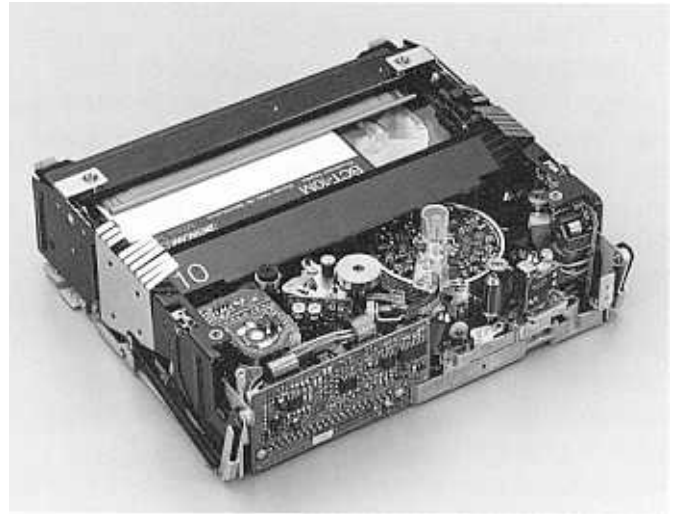

3-3. VTR Electronic Features

3-3-1. Plug-in PC board construction

Each head amplifier, which handles very small signals, is located close to its video heads and audio heads, and these signals are amplified to be fed to the signal processing circuitry. Therefore, the head amplifier is immune to interference from other electronic circuits. The motor drive circuit and the full-erase oscillator, which handle relatively high power signals, are also located so close to their associated components. The interference between electronic circuits is greatly reduced in this way. This enables PC boards of both the camera and VTR sections to be plugged into the same motherboard. Thus, most of the harness connections are eliminated and reliability is thereby remarkably enhanced.

3-3-2. Software servo control IC

The drum servo, capstan servo, and the mechanical deck are all controlled by newly developed IC's under software control. The use of these powerful IC's drastically reduced the number of electronic components in the servo control and system control circuitry. This also contributed to the weight reduction and lowered power consumption.

3-3-3. Serial interface among CPU's

The BVW-200/300/400 utilize a total of four CPU's for camera control, VTR system control, servo control, and operational control. These CPU's use a common serial data bus interface. This intelligent interface among the CPU's greatly reduces the need for wiring harnesses. Also, the common data bus that links the camera CPU to the three CPU's employed in the VTR permit a sophisticated diagnostic system to be realized in the camcorder.

3-3-4. High density circuit board

Use of the latest manufacturing process permits the one-piece camcorders to extensively use newly developed HIC (Hybrid Integrated Circuits) and IC. This not only contributes to the one-piece camcorder's compact and lightweight design, but also plays an important role in the reduction of power consumption. The BVW-200/300/400 use only one Video Modulator IC for each channel, while previous models required three. In order to realize the small 4-head drum, newly developed Rec/playback HIC and Playback Amplifier Control IC are built into the drum. The IC's and HIC's for CTDM (Compressed Time Division Multiplex) are also newly developed.

The direct bonding of IC chips, used in the HIC, is also effective to reduce the overall weight, size, and power consumption.

In order to obtain even higher packing density of the electronic circuitry, the PC boards use chip resistors and

capacitors. Double Sided Surface Mounting of the components and 4 layer PC board construction are used on the main PC boards.

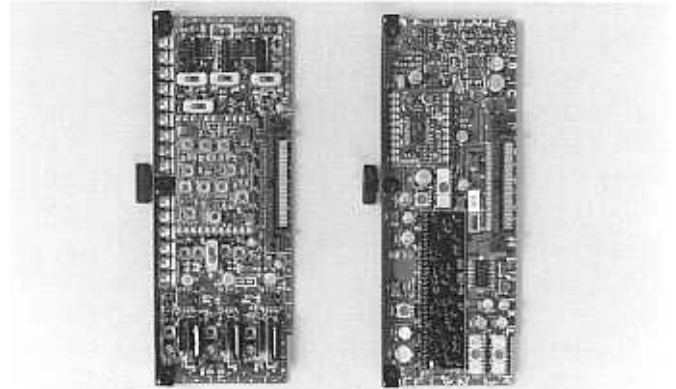

3-3-5. LCD multiple displays

The displays used for the one-piece camcorder have also been carefully designed. The BVW-200/300/400 employ a specially selected LCD which works even at low temperatures.

The following indications are provided in the LCD multiple display area.

- Time code—8 digits
- Time code status
- Audio 2 CH—16 segments × 2 CH
- Battery status—7 segments
- VTR warning indication

Two-channel Audio level and Battery status are displayed on a Bargraph meter that can be read at a glance.



3-4. Camera Technical Features

3-4-1. Camera head construction

The camera section consists of a compact optical block with 3 CCD imagers, six plug-in PC boards which share the same motherboard with those of the VTR section, and a viewfinder.

Large Scale Hybrid Integrated Circuits such as DCC (Dynamic Contrast Control) HIC and Shading HIC, and high density mounting technology are employed to reduce the overall PC board surface space to 70% of the space in conventional cameras.

All the advantages of CCD imager cameras; rugged operation, high stability, weight and size reduction are also provided in the BVW-200/300/400 One-piece Camcorders.

3-4-2. Advanced Sony's CCD technology

The BVW-200/300/400 feature a multitude of advantages from the use of Sony's CCD technology. The followings are their general advantages.

- No problem of image burn-in or lag
- Impervious to vibration and shock
- Inherent immunity to strong electric or magnetic fields
- Freedom from registration adjustment

The new of one-piece camcorder BVW-400 adopts the high resolution 768(H) × 494(V) pixel FIT (Frame Interline Transfer) HAD (Hole Accumulated Diode) sensor CCD's for the most complex and quality conscious type of field production. The BVW-300 is designed to be used for ENG and EFP applications. The CCD device used in the BVW-300 is the 768(H) × 493(V) pixel IT (Interline Transfer) CCD combined with the same HAD sensor technology as the BVW-400 CCD. Sony's unique CCD technology employed in the BVW-300/400 is described in detail below.

• HAD sensor

The HAD sensor is a diode sensor which incorporates a Hole Accumulated layer on its surface. This layer is very effective in reducing dark current. The total dark current noise of the HAD sensors is reduced to 1/10 that of conventional CCD's. This reduction gives a corresponding reduction in the fixed pattern noise, and a high signal-to-noise ratio. Lag effects are also significantly reduced by the use of this sensor.

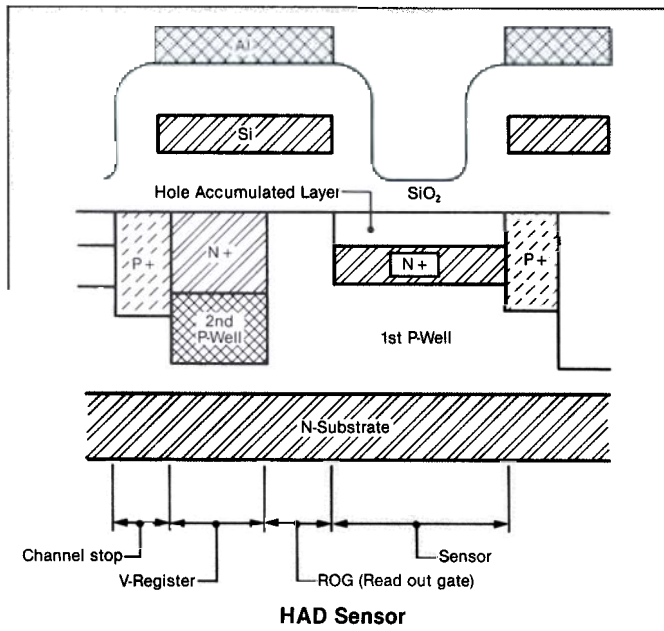

• Variable speed electronic shutter

The BVW-300/400 are provided with a variable speed electronic shutter built into the CCD imager. This shutter enables the BVW-300/400 to capture clear images of high speed movement giving remarkable improvement in the dynamic resolution of moving objects. Clear playback of still or slow-motion pictures can be obtained.

The variable shutter speed is easily selected by a front panel switch.

• High resolution

The remarkably high horizontal luminance resolution of 700 TV lines is achieved by the use of high density CCD chips and Sony's Spatial Offset technology.

• High sensitivity

In the HAD sensor CCD, the use of a vertical Overflow Drain increases the sensor aperture ratio (the photosensitive part of the CCD area). Thus, this structure combines high sensitivity with high resolution.

• Ideal color reproduction

Improvements to CCD spectral response make it possible to achieve colorimetry which closely approximates that of Plumbicon™ cameras.

• FIT charge transfer technique (for BVW-400)

An FIT structure incorporated in the BVW-400 CCD's has a separate field memory between the image sensing area, with its associated vertical shift registers, and the horizontal output shift register. The charge information is rapidly transferred from the vertical registers into this separate field store, which is protected by an opaque mask. This prevents highlight corruption of the charge information while it is clocked into the horizontal output register. Due to this rapid transfer technique, highlight smear is reduced to a level of -120dB, at which it is practically invisible.

The BVW-200 was designed primarily for shoulder mounted ENG application. Therefore, the design focused on aspects relating to proven reliability and optimum compromise between cost and performance. For this reason, the 510(H) × 492(V) pixel IT CCD is used. Please refer to the specification table in Chapter 8 for detailed specifications of each of the one-piece camcorders.

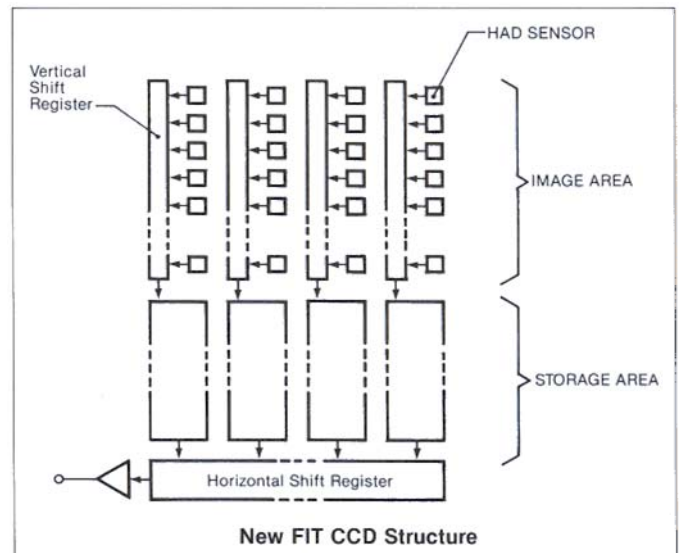

4 EASY OPERATION

4-1. Refined Ergonomics

The careful consideration of the Sony design team has had a marked effect on the ergonomic design of the BVW-200/300/400. This is reflected in the basic shape and construction, as well as the layout of the operational controls in the units. Considering the need for enhanced mobility and comfortable operation, the length has been held to a mere 370mm (from lens mount to rear of battery), and the overall maximum height is 268mm, with a low center of gravity. The low profile front-end ensures good visibility in all direction for the operator when used on the shoulder, and its short length enables well-balanced operation. In order to accommodate the use of different lenses and battery systems, the shoulder pad position is adjustable for perfect balance.

A large carrying handle has been provided in order to provide security during transport and to allow easy handling in low angle shooting.

The body is made of rugged diecast magnesium to prevent interference, and to realize light weight and durability. The operational controls have been carefully positioned on the body of the BVW-200/300/400, with particular care to the location of those primary controls accessed while shooting from the shoulder. Even the audio level controls can be easily adjusted by comfortably reaching behind the unit.

4-2. Rain and Dust-proof Structure

Each joint of the camcorder is sealed with rubber gasketing to resist water and dust. This strong rain/dust-proof structure is ideal for field use including ENG and location work in harsh environments.

4-3. Quick Start Viewfinder

4-3-1. Optical/CRT

Special attention was paid to the design of the viewfinder. The innovative 1.5" monochrome viewfinder supplied with the one-piece camcorders is designed to increase operational ease. The CRT produces 550 TV lines of center resolution which, together with a variable phase corrected peaking control (Dual edge peaking correction), considerably improves the camera person's focusing role. A larger 2 inch optical lens is fitted to the front of the viewfinder. This allows operators to see the full raster including the corners, even when positioned behind the camera. A wide range of diopter adjustment (-3.8~ +0.3) is provided to compensate for differences in eye sight.

Furthermore, this viewfinder presents a stable picture within only one second from a cold start. Coupled with the instant response CCD chip, this means that the BVW-200/300/400 are capable of capturing images within one second from 'power-on'. This allows the pre-

heat function to be eliminated from the unit. In this way, the ability to capture important, unrepeatable action is greatly enhanced.

4-3-2. Viewfinder mechanism

The unique viewfinder mount enables movement in the forward/backward direction as well as lateral adjustment. Moreover, the viewfinder can also be tilted plus and minus 90 degrees. The BVW-400 features a viewfinder rotation mechanism, when equipped with the optional BKW-401 Viewfinder Rotation Bracket, so that the viewfinder will not strike the operator's leg while carried*. In addition, the eye-piece of the BVW-400's viewfinder can be easily removed for ease of cleaning and to provide direct observation of the CRT from a distance.

*This function will also come available for the BVW-200/300. For further information, please contact the Sony office nearest you.

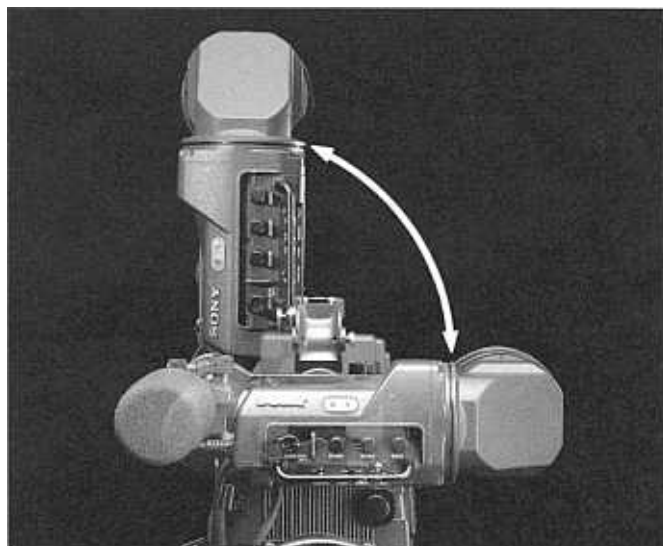

BVW-400 Viewfinder Rotation mechanism with the BKW-401

4-3-3. Operational facilities

The ergonomic improvements of the BVW-200/300/400 camcorders also extend to the alpha-numeric readouts within the viewfinder. The readout can be selected to report on a wide range of operational conditions including: rec status, battery alarm, Audio level (ch-1), Videl level, the preselected color-balance memory, tape time remaining, filter position, gain settings, shutter speed (for BVW-300/400 only), and VTR save mode (for BVW-400 only). The BVW-400's viewfinder also provides a center marker and a 80% or 90% safety zone indications.

BVW-400 Viewfinder Indications



4-4. Detachable Microphone

The built-in microphone can be detached from the unit to be used in interview situations. The optional extension cable permits any style of interview without the need for another external microphone. The newly developed built-in anti-vibration circuitry greatly reduces the vibration noise from the VTR portion when shooting. Phantom power is also provided.

4-5. Tally Lamp

The BVW-200/300/400 are provided with a tally lamp newly located in the rear of the carrying handle in addition to that in front of the viewfinder. This rear tally lamp is a very useful indicator for use by crews behind the camera operator. On/off switches for the tally lamps are provided individually and the front tally's brightness is adjustable High or Low.

4-6. Battery for Time Code Back-up

Thanks to the use of a lithium battery in conjunction with super capacitor, the BVW-200/300/400 maintain time code memory for approximately five years without an external power supply.

4-7. Other Operational Facilities

4-7-1. VTR section

- PLAYBACK
 - Viewfinder playback (Luminance or CTDM Chroma)
 - Color playback using the optional VA-500 Playback Adaptor
 - Audio confidence playback during recording
- EDITING

Back space edit plus recording review. Back space editing is possible from any point within the recorded material, even if the power is turned off or a cassette is taken out and reinserted.
- TRANSPORT CONTROLS

Eject, play, rewind, fast forward, stop controls are protected by a safety lid and inhibited during record mode.
- AUDIO
 - 2 input channels; each channel recorded on both longitudinal and AFM channel
 - Dolby™ C-Type Noise Reduction system
 - Auto and manual level control with bargraph audio metering
 - Built-in loudspeaker with level control
 - Additional audio channel 1 level control on viewfinder
 - 2 external inputs with XLR connectors and switchable phantom power supply (+ 48V)

- TIME CODE
 - LTC/VITC/User's bit generator
 - LTC reader
 - Real time clock
 - External time code lock capability

4-7-2. Camera section

- TEST & COLOR BARS
 - Switchable sawtooth test waveform
 - Switchable SMPTE type color bars
- AUTO-SYSTEMS
 - Auto white balance
 - Two preset memories for each filter wheel position
 - Auto black balance
 - Switchable automatic dynamic contrast control for up to 600% highlight overload
- GAIN
 - Switchable 0, +9, +18
 - (selectable to +24dB internally)
- SHUTTER (for BVW-300/400)
 - Switchable: OFF or 6 preset speeds
 - ($1/100$, $1/125$, $1/250$, $1/500$, $1/1000$, $1/2000$ seconds)
- FULL COLOR GENLOCK for multi-camera shooting (for BVW-300/400)
- CAMERA CONTROL by simple control panel RM-P3

4-7-3. Exclusive features for BVW-400

- 1) FIT type CCD employed greatly reduces the vertical smear level to -120dB.
- 2) Detachable viewfinder eyepiece
- 3) Viewfinder center marker, safety zone marker (80% or 90% selectable), and VTR save mode indication
- 4) 26-pin VTR interface with the optional BKW-402 VTR Connector Unit
 - Camera component out signals are supplied.
 - Parallel component recording with the external VTR is possible (start/stop function of external VTR is also controlled from the BVW-400).
 - Warning indications of both the BVW-400 and external VTR are provided in the BVW-400 viewfinder.

5. EASY MAINTENANCE AND ADVANCED SERVICEABILITY

The BWV-200/300/400 require an absolute minimum of routine maintenance and there is no need for daily re-alignment of any kind. Both in the camera and the recorder section, all electronics are modular, being located on plug-in PC boards. Also, CCD sensors are stable and do not deteriorate.

Both sections share the same motherboard, which allows a unique approach to implementing a diagnostics system. The diagnostics system permits rapid and precise fault location in both VTR and camera sections. Various modes of diagnostics system can be selected and executed via the Time Code Advance/Shift key. The status can be displayed on the LCD character display or in the viewfinder.

6. EXCELLENT EXPANDABILITY

The BWV-200/300/400 accept a variety of accessories to suit a wide range of shooting styles. Users can select the most suitable one to match their specific applications. Moreover, the BWV-300/400 are provided with the capability to feed the camera signals to an external recorder. In the unlikely event of transport failure, a BWV-35 can be controlled from the BWV-300/400 as a back-up VTR via the optional CCRZ-5 Connecting Cable. In this case, the VTR portion of the BWV-300/400 is automatically disabled.

The BWV-400 is also provided with the 26-pin VTR interface capability by using the optional BKW-402 VTR Connector Unit. Simultaneous component recording by both the BWV-400 and the external VTR is possible. In this case, VTR start/stop function of both VTRs can be controlled from the BWV-400 camera portion.



26-pin interface between the BWV-400 with the BKW-402 and the BWV-35 via the CCZ cable

System Configuration

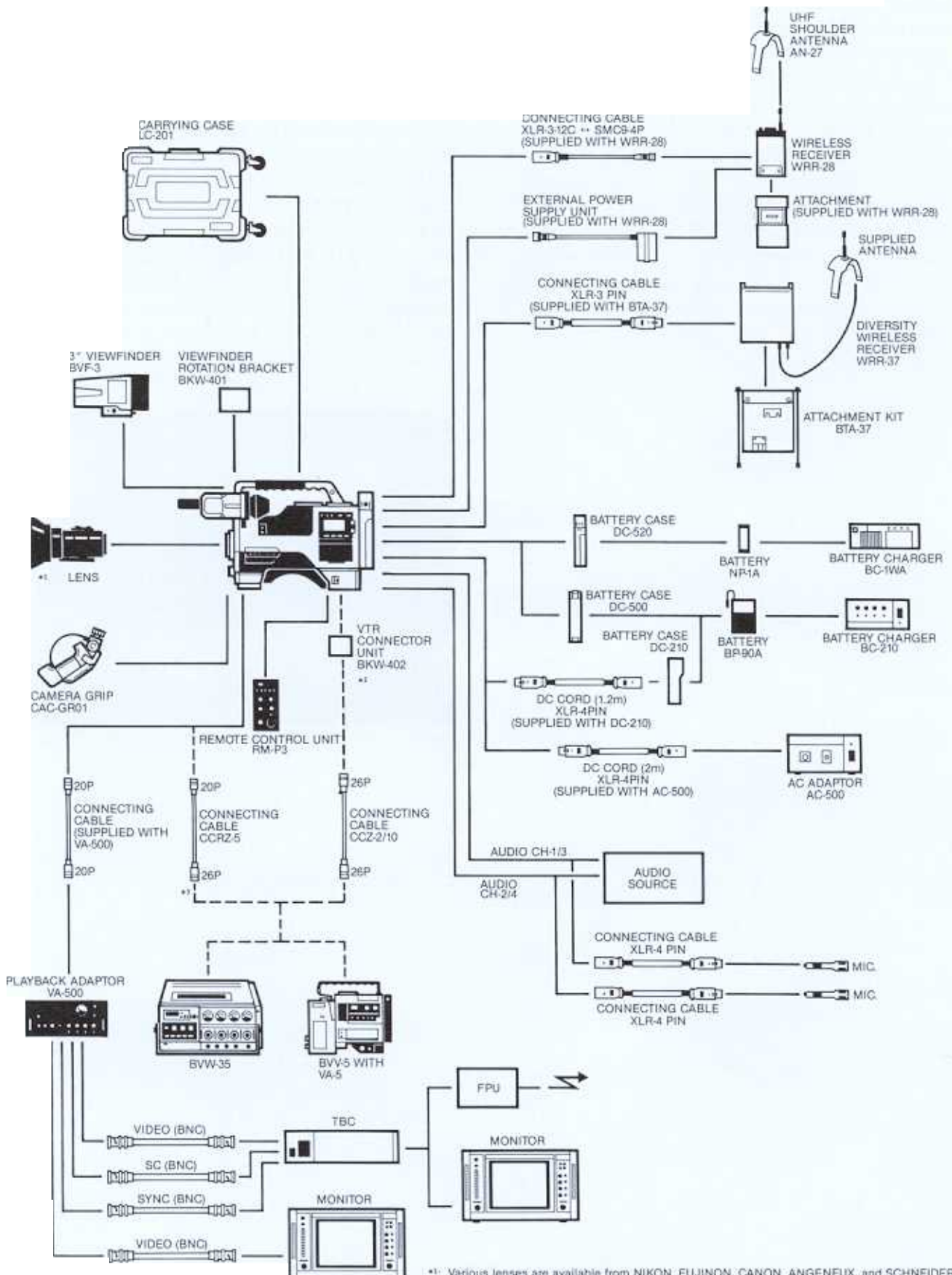

*1: Various lenses are available from NIKON, FUJINON, CANON, ANGENEUX, and SCHNEIDER.
 *2: This function is available only for BVW-400.
 *3: This function is available only for BVW-300/400.

Optional Accessories

For BVW-200/300/400



BP-90A
Rechargeable NiCd Battery



NP-1A
Rechargeable NiCd Battery



BC-1WA
Battery charger for NP-1A



BC-210
Battery Charger for BP-90A



AC-500
AC Adaptor



DC-210 (Waist Belt Type)
Battery Case for BP-90A



DC-500 (Mount Type)
Battery Case for BP-90A



DC-520 (Mount Type)
Battery Case for NP-1A x 2



VA-500
Playback Adaptor



WRR-28
Wireless Microphone Receiver



AN-27
UHF Shoulder Antenna



WRR-37
Diversity Wireless Receiver

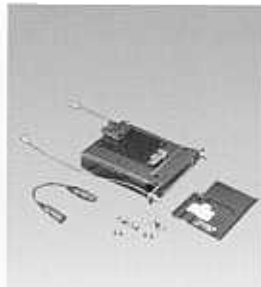

BTA-37
Attachment Kit for WRR-37



RM-P3
Remote Control Unit



BVF-3
3" Viewfinder



CAC-GR01
Camera Grip



BKW-401*1
Viewfinder Rotation Bracket



LC-201*2
Carrying Case



BCT-5M/10M/20M/30M
Betacam Tape (Metal)



BCT-5G/10G/20G/30G
Betacam Tape (Oxide)

For BVW-300/400



CCRZ-5 (5m)
BVW-35 Connecting Cable
(20 pin—26 pin)

For BVW-400 only



BKW-402
VTR Connector Unit (26 pin)



CCZ-2/10 (2m/10m)
Connecting Cable (26 pin—26 pin)

*1 For the BVW-200/300 this model will come available in the near future.

*2 This model is not available in some areas.

For further information on the above, please contact the Sony office nearest you.

7. EXPLANATION OF BVW-200/300/400 FUNCTION KEYS AND BUTTONS (Photo shows the BVW-400)

- ❶ AUDIO LEVEL CH-1 control
- ❷ PEAKING control (on/off and volume control)
- ❸ Tally lamp
- ❹ CONTRAST control
- ❺ BRIGHT control
- ❻ AUDIO (audio channel-1 recording level) and TAPE (tape remaining time) INDICATOR switch
- ❼ ZEBRA, MARKER switch (ZEBRA switch for BVW-200/300)
- ❽ TALLY switch (high, low, or off selectable)
- ❾ VTR START button
- ❿ SHUTTER selector (for BVW-300/400)
- ⓫ AUTO W/B BAL (automatic white/black balance adjustment) switch
- ⓬ FILTER selector
- ⓭ ALARM control
- ⓮ MONITOR control
- ⓯ Speaker
- ⓰ EJECT button
- ⓱ REW (rewind) button and lamp
- ⓲ FFWD (fast forward) button and lamp
- ⓳ PLAY (playback) button and lamp
- ⓴ STOP button
- ⓵ WARNING lamp
- ⓶ HOLD (display hold) button
- ⓷ RESET (counter reset) button
- ⓸ DISPLAY switch (User bit, Time code, or CTL selectable)
- ⓹ LIGHT switch
- ⓺ LCD display window
- ⓻ AUDIO LEVEL CH-1 and CH-2 (audio channel 1 and channel 2 recording level) controls
- ⓼ MONITOR SELECT switch (Audio CH-1, MIX or CH-2 selectable)
- ⓽ MONITOR switch (PB (playback sound during recording) or E-E sound selectable)
- ⓿ AUDIO SELECT CH-1 and CH-2 switches (Auto or manual level adjustment selectable, respectively)
- ⓾ ADVANCE button (To set Time Code or User bit)
- ⓿ SHIFT button (To set Time Code or User bit)
- ⓿ DIAGNOSTIC switch
- ⓿ DF/NDF (drop frame/non drop frame) switch
- ⓿ AUDIO IN (input) switches (Select audio input signals from the FRONT-MIC (microphone connected to MIC IN connector), REAR MIC (microphone connected to AUDIO IN CH-1 or CH-2 connector), REAR-LINE (audio source connected to AUDIO IN CH-1 or CH-2 connector))
- ⓿ VITC (VITC line setting) controls
- ⓿ F-RUN/R-RUN (free run/recording run) switch
- ⓿ REAL TIME (time of the day) switch
- ⓿ DOLBY NR switch
- ⓿ VTR (VTR power mode) switch (STAND BY mode or SAVE mode selectable)
- ⓿ GAIN selector (0/9/18dB)
- ⓿ OUTPUT/DCC (output signal/Dynamic Contrast Control) selector
- ⓿ WHITE BAL (balance memory) selector
- ⓿ CTDM (Compressed Time Division Multiplex) playback button
- ⓿ POWER switch
- ⓿ EARPHONE jack (mini jack)
- ⓿ Battery case for NP-1A
- ⓿ DC IN (external power input) connector (XLR 4-pin, Male) (Connects the DC power cord of the optional AC-500 AC adaptor when operating on AC power)
- ⓿ DC OUT connector (Supplies DC power to the optional wireless microphone)
- ⓿ VIDEO OUT connector (BNC)
- ⓿ Phantom switches
- ⓿ AUDIO IN CH-1 and AUDIO IN CH-2 connectors (XLR 3-pin, Female)
- ⓿ Back tally lamp switch (ON/OFF)
- ⓿ Back tally lamp
- ⓿ Hooks for shoulder strap
- ⓿ Light shoe (To attach a video light)
- ⓿ Lens mount (special bayonet type)
- ⓿ REMOTE connector (6-pin) (Connects the optional RM-P3 Remote Control Unit)
- ⓿ Shoulder pad
- ⓿ GENLOCK VIDEO IN connector (BNC) (TC LOCK VIDEO IN connector for BVW-200)
- ⓿ VIDEO OUT connector (BNC)
- ⓿ TC IN (Time code input for time code lock) connector (BNC)
- ⓿ TC OUT (time code output for time code lock) connector (BNC)
- ⓿ PB ADAPTOR (playback adaptor) connector (20-pin)
- ⓿ MIC IN connector (XLR 3-pin, female)
- ⓿ PEDESTAL control
- ⓿ LENS connector (12-pin)
- ⓿ Tripod mount

